

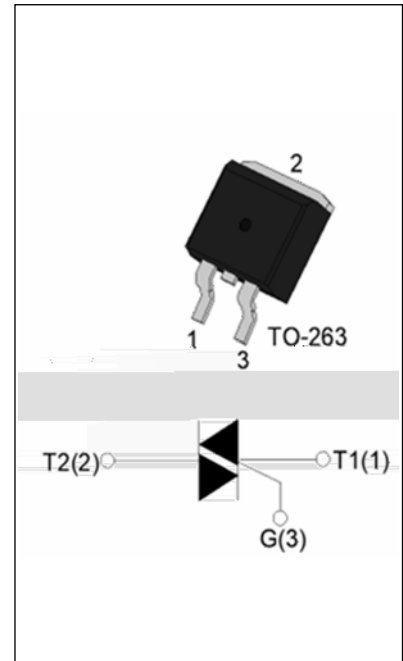

| | | |
|----------|--|--|
| | | |
| | | |
| | | |
| I II III | | |



| Parameter | Symbol | Value | Unit |
|-----------|--------|-------|------|
| | | | °C |
| | | | °C |
| | | | °C |
| | | | °C |
| | | | ≤ °C |
| | | | °C |
| | | | °C |
| | | | °C |
| × | | | °C |
| | | | °C |
| | | | °C |
| | | | °C |
| | | | °C |

°C

| Symbol | Test Condition | Quadrant | Value | | Unit |
|--------|----------------|----------|-------|--|------|
| | | I II III | | | |
| | | I II III | | | |
| | °C | I II III | | | |
| | | I III | | | |
| | | II | | | |
| | | | | | |
| | | °C | | | |
| | | °C | | | |
| | | | | | |
| | °C | | | | |
| | | | | | |

| Symbol | Parameter | | Value(MAX.) | Unit |
|--------|-----------|----|-------------|------|
| | | °C | | |
| | | °C | | |
| | | °C | | |
| | | °C | | |
| | | °C | | |

| Symbol | Parameter | Value | Unit |
|--------|-----------|-------|------|
| | | | °C |
| | | | °C |

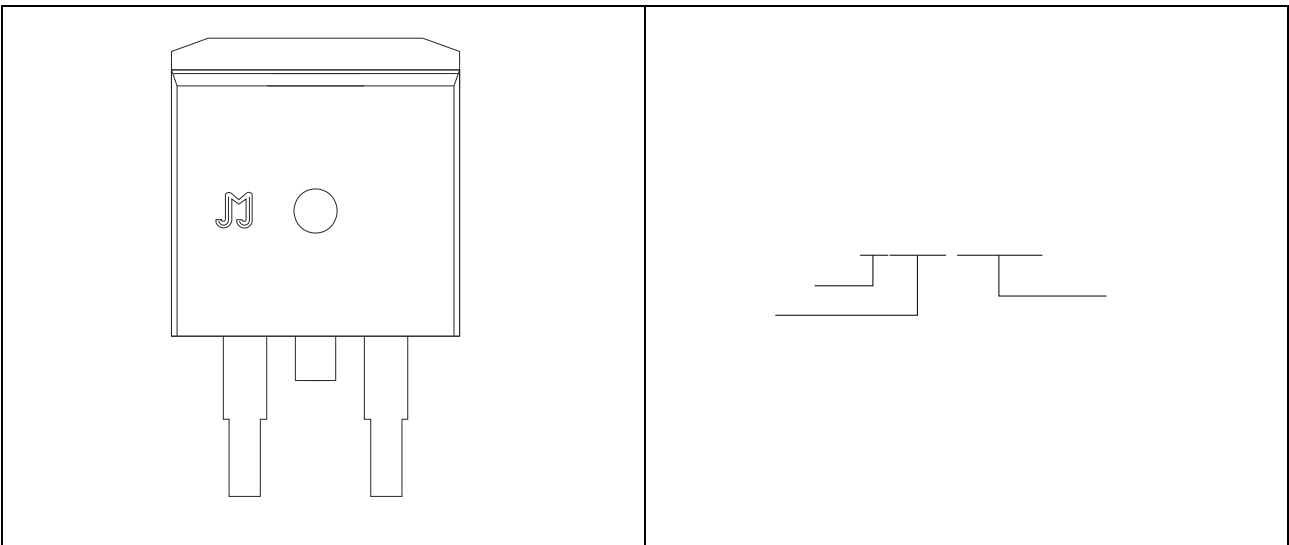
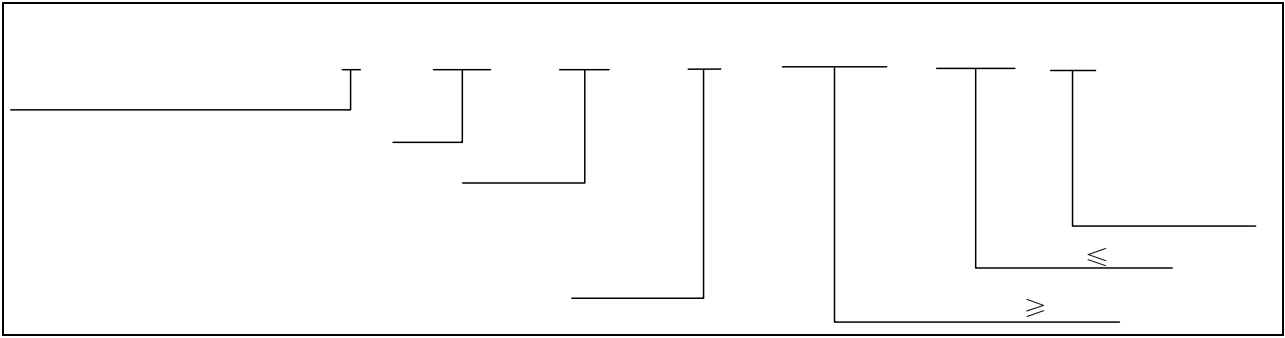

FIG.1

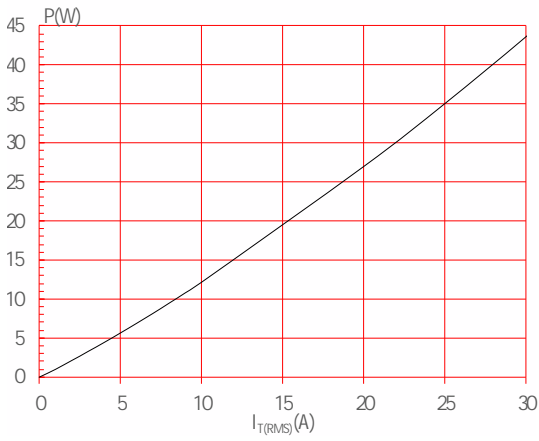

FIG.2:

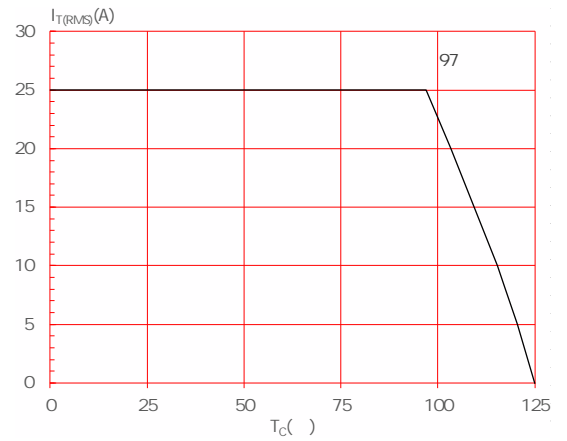

FIG.3:

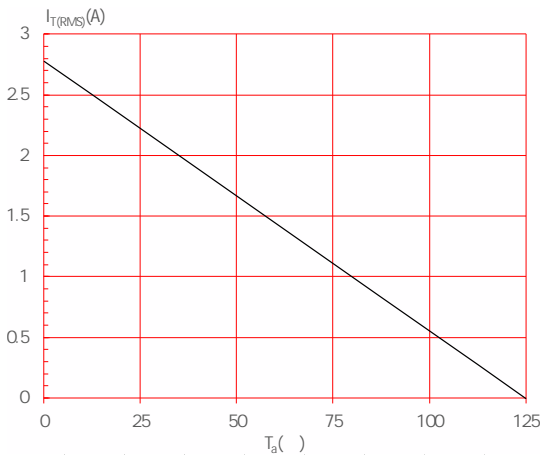

FIG.4:

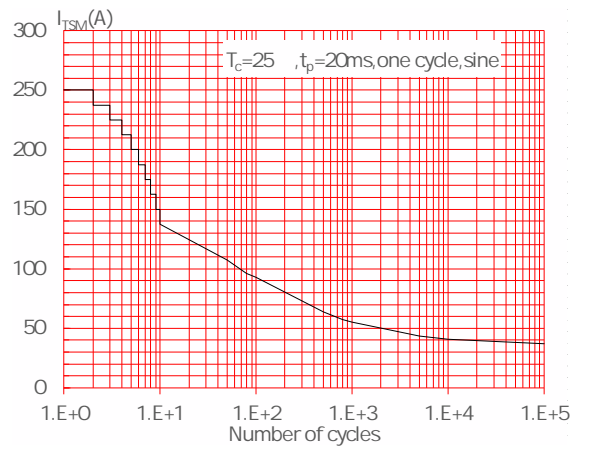

FIG.5:

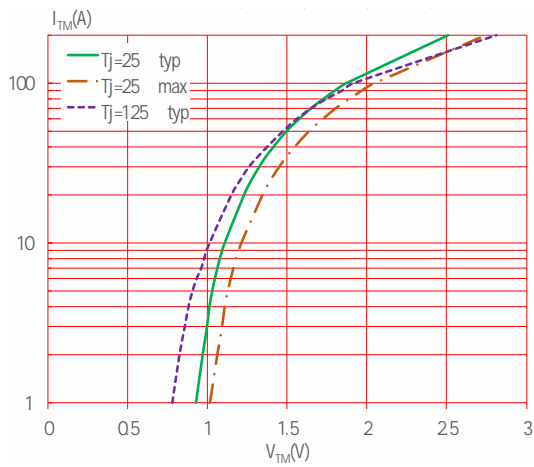

FIG.6:

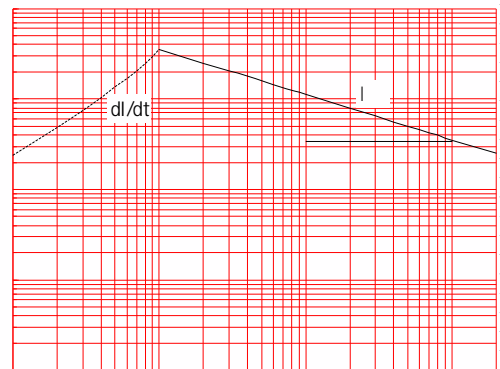
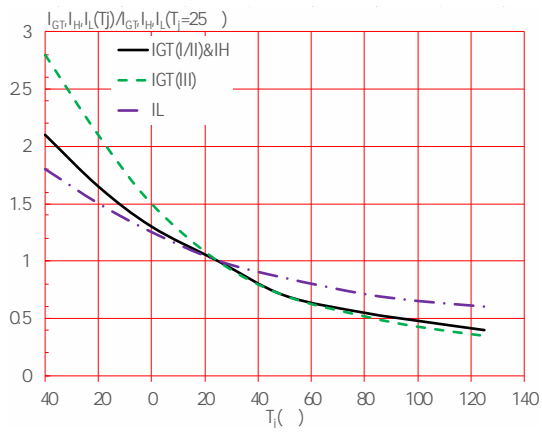
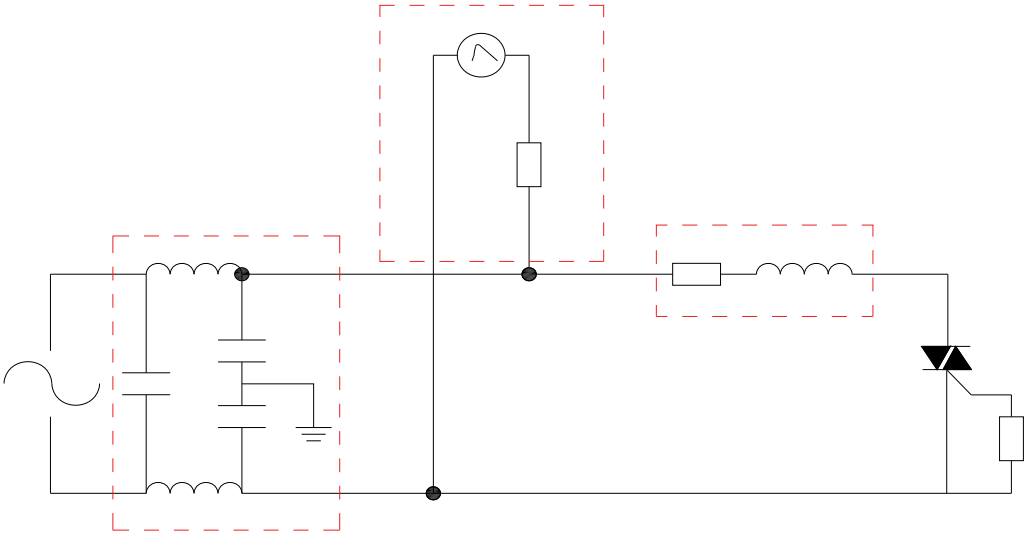

FIG.7:



:



| Order code | Voltage V _{DRM} /V _{RRM} (V) | IGT(mA) | Package | Base qty. (pcs) | Delivery mode |
|------------------|---|---------|---------|--------------------|---------------|
| | | - - | | | |
| JST24E-1200BW | 1200 | 50 | TO-263 | 50 | Tube |
| JST24E-1200BW-TR | | | | 800 | Tape & Reel |

Document Revision History

| Document Revision History | | |
|---------------------------|--|--|
| | | |

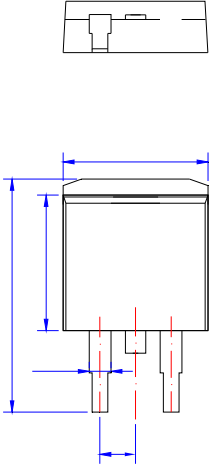

| | | | | | |
|--|--|--|--|--|--|
| | | | | | |
| | | | | | |
| | | | | | |
| | | | | | |
| | | | | | |
| | | | | | |
| | | | | | |
| | | | | | |
| | | | | | |
| | | | | | |
| | | | | | |
| | | | | | |
| | | | | | |
| | | | | | |
| | | | | | |
| | | | | | |
| | | | | | |
| | | | | | |
| | | | | | |
| | | | | | |
| | | | | | |
| | | | | | |

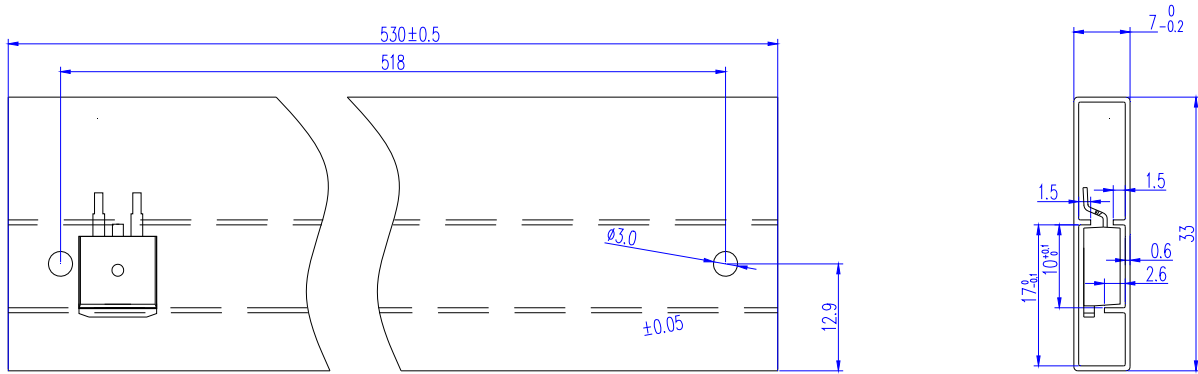

| PACKAGE | OUTLINE | TUBE (PCS) | INNER BOX (PCS) | PER CARTON |
|---------|---------|------------|-----------------|------------|
| | | | | |

