



## T2050H-6F 20A TRIAC

Rev.A.1.0

### DESCRIPTION:

The T2050H-6F triac is suitable for general purpose AC switching. It can be used as an ON/OFF function in applications such as heating regulation, induction motor starting circuits, for phase control operation in light dimmers, motor speed controllers. Compared to traditional triacs, T2050H-6F provides a very high switching capability up to junction temperatures of 150°C. By using an external plastic package, T2050H-6F provides a rated insulation voltage of 2000 VRMS, complying with UL standards (File ref: E252906). Package TO-220F is RoHS compliant.

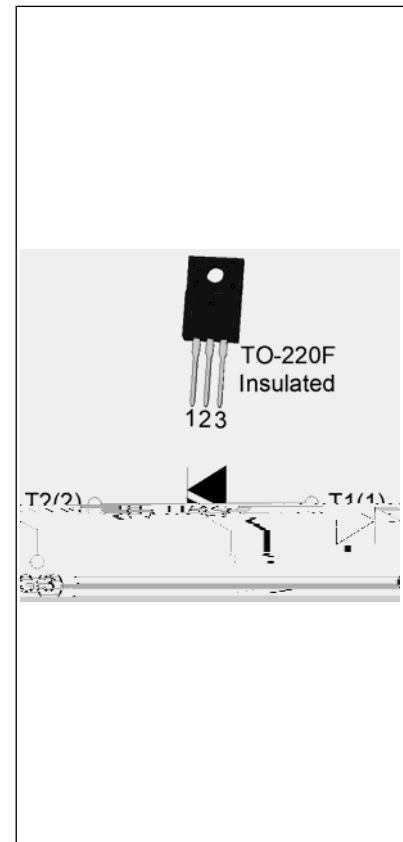

### MAIN FEATURES

Symbol	Value	Unit
$I_{T(RMS)}$	20	A
$V_{DRM}/V_{RRM}$	600	V
$I_{GT} / /$	50/50/50	mA

### ABSOLUTE MAXIMUM RATINGS

Parameter	Symbol	Value	Unit
Storage junction temperature range	$T_{stg}$	-40-150	
Operating junction temperature range	$T_j$	-40-150	
Repetitive peak off-state voltage ( $T_j=25^\circ\text{C}$ )	$V_{DRM}$	600	V
Repetitive peak reverse voltage ( $T_j=25^\circ\text{C}$ )	$V_{RRM}$	600	V
RMS on-state current ( $T_c = 87^\circ\text{C}$ )	$I_{T(RMS)}$	20	A
Non repetitive surge peak on-state current (full cycle, $t_p=20\text{ms}$ , $T_j=25^\circ\text{C}$ )	$I_{TSM}$	200	A
Non repetitive surge peak on-state current (full cycle, $t_p=16.6\text{ms}$ , $T_j=25^\circ\text{C}$ )		220	
$I^2t$ value for fusing ( $t_p=10\text{ms}$ , $T_j=25^\circ\text{C}$ )	$I^2t$	200	$\text{A}^2\text{s}$
Critical rate of rise of on-state current ( $I_G=2 \times I_{GT}$ , $f=100\text{Hz}$ , $T_j=150^\circ\text{C}$ )	$di/dt$	100	$\text{A}/\mu\text{s}$
Peak gate current ( $t_p=20\mu\text{s}$ , $T_j=150^\circ\text{C}$ )	$I_{GM}$	4	A

Average gate power dissipation ( $T_j=150$ )	$P_{G(AV)}$	1	W
Peak gate power	$P_{GM}$	10	W
Peak pulse voltage ( $T_j=25$ ; non-repetitive, off-state; FIG.7)	$V_{pp}$	4	kV

**ELECTRICAL CHARACTERISTICS** ( $T_j=25$  unless otherwise specified)

Symbol	Test Condition	Quadrant	Value		Unit
$I_{GT}$	$V_D=12V R_L=33$	- -	MAX.	50	mA
$V_{GT}$		- -	MAX.	1	V
$V_{GD}$	$V_D=V_{DRM} T_j=150$ $R_L=3.3K$	- -	MIN.	0.2	V
$I_L$	$I_G=1.2I_{GT}$	-	MAX.	70	mA
				100	
$I_H$	$I_T=500mA$		MAX.	60	mA
dV/dt	$V_D=400V$ Gate Open $T_j=150$		MIN.	2200	V/ $\mu s$
(dI/dt) <sub>c</sub>	(dV/dt) <sub>c</sub> =20V/ $\mu s$ , $T_j=150$		MIN.	30	A/ms
$t_{on}$	$I_G=80mA I_A=400mA I_R=40mA$ $T_j=25$		TYP.	12	$\mu s$
$t_{off}$				90	

**STATIC CHARACTERISTICS**

Symbol	Parameter		Value(MAX.)	Unit
$V_{TM}$	$I_{TM}=28A t_p=380\mu s$	$T_j=25$	1.4	V
$V_{TO}$	Threshold voltage	$T_j=150$	0.71	V
$R_D$	Dynamic resistance	$T_j=150$	22	m
$I_{DRM}$	$V_D=V_{DRM} V_R=V_{RRM}$	$T_j=25$	5	$\mu A$
$I_{RRM}$		$T_j=150$	2.5	mA

**THERMAL RESISTANCES**

Symbol	Parameter	Value	Unit
$R_{th(j-c)}$	junction to case (AC)	2.4	/W
$R_{th(j-a)}$	junction to ambient (AC)	60	/W

**ORDERING INFORMATION**

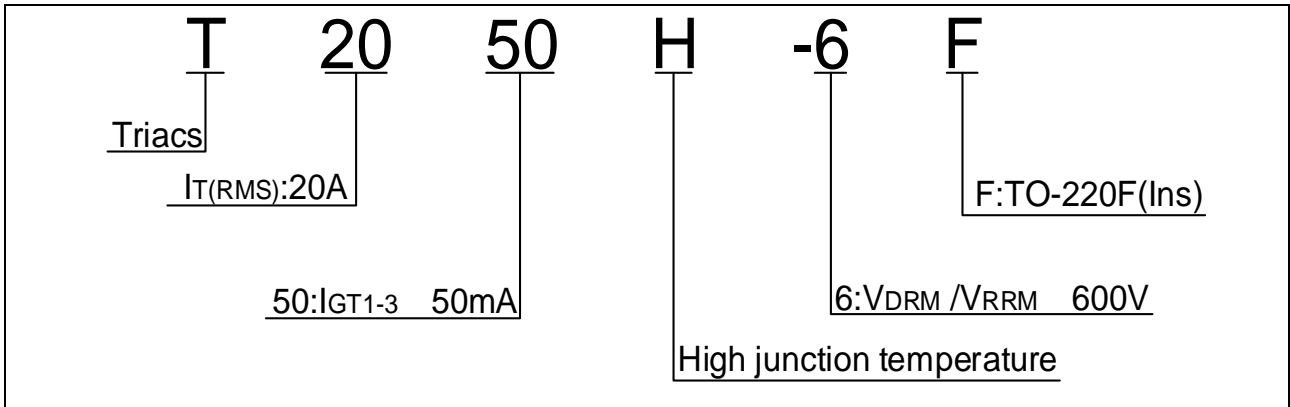

**MARKING**

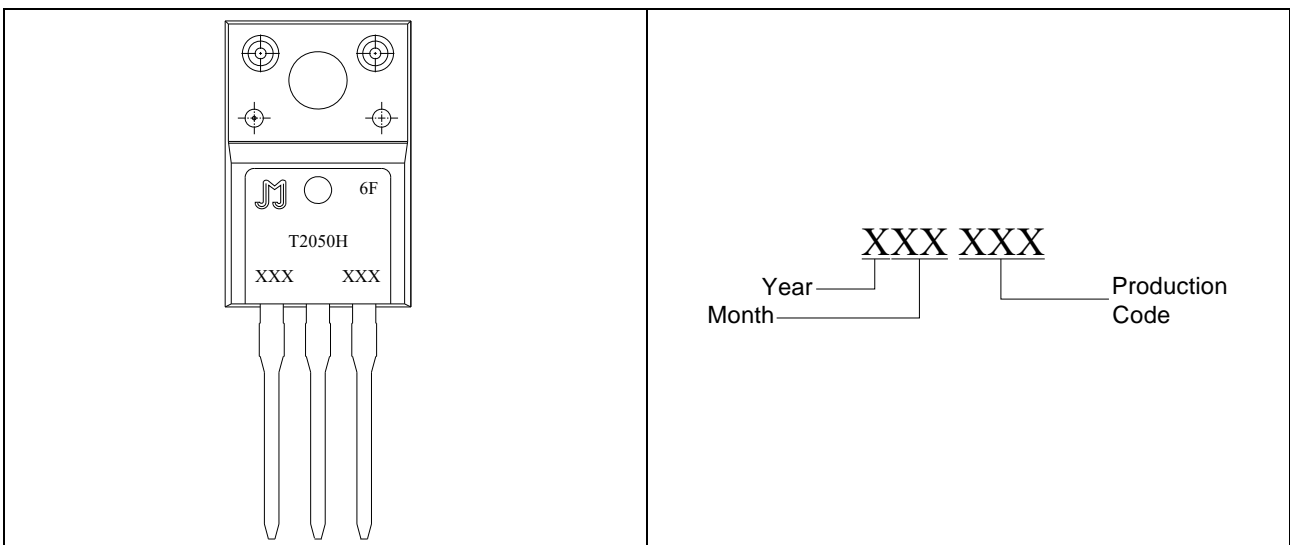

**FIG.1** Maximum power dissipation versus RMS on-state current

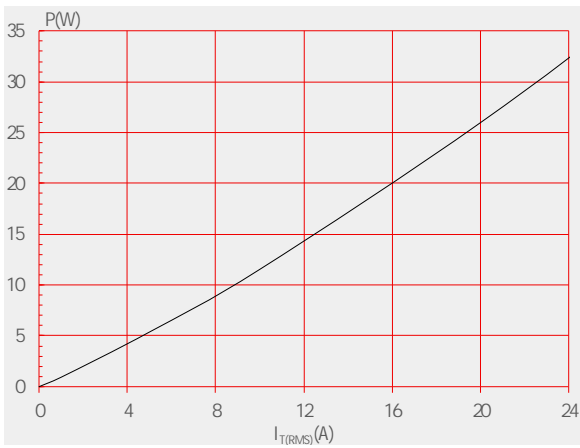

**FIG.3:** Surge peak on-state current versus number of cycles

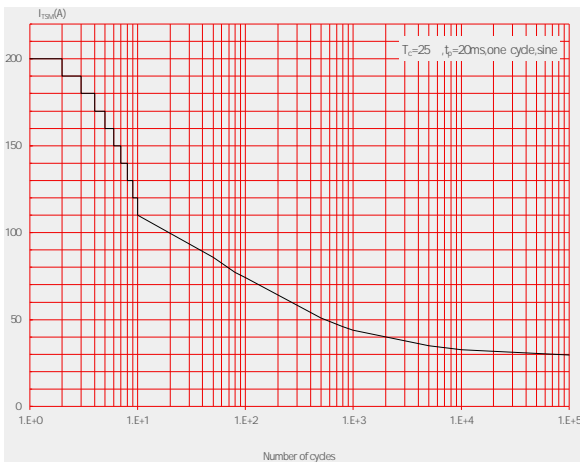

**FIG.5:** Non-repetitive surge peak on-state current for a sinusoidal pulse with width  $t_p < 20\text{ms}$ , and corresponding value of  $I^2t$  ( $di/dt < 100\text{A}/\mu\text{s}$ )

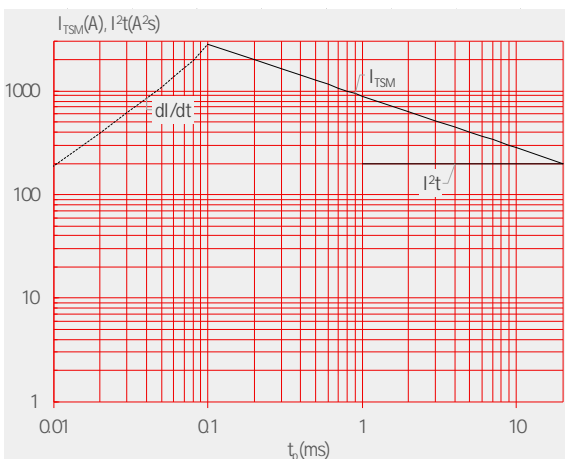

**FIG.2:** RMS on-state current versus case temperature

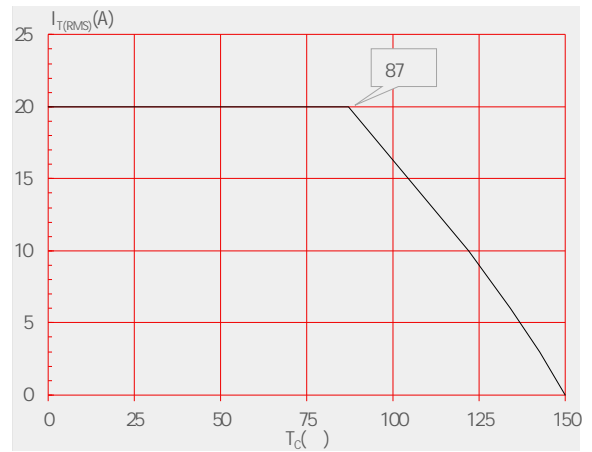

**FIG.4:** On-state characteristics

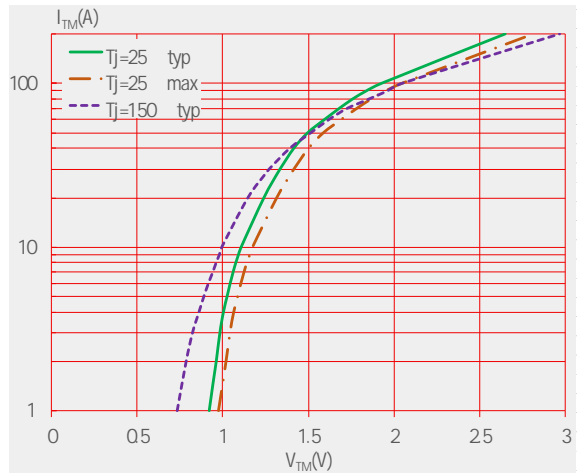

**FIG.6:** Relative variations of gate trigger current, holding current and latching current versus junction temperature

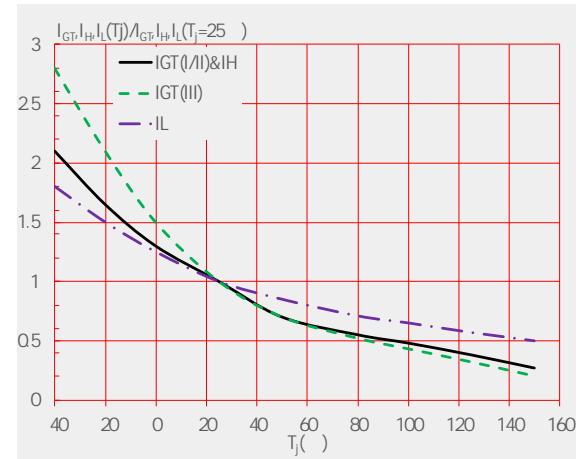
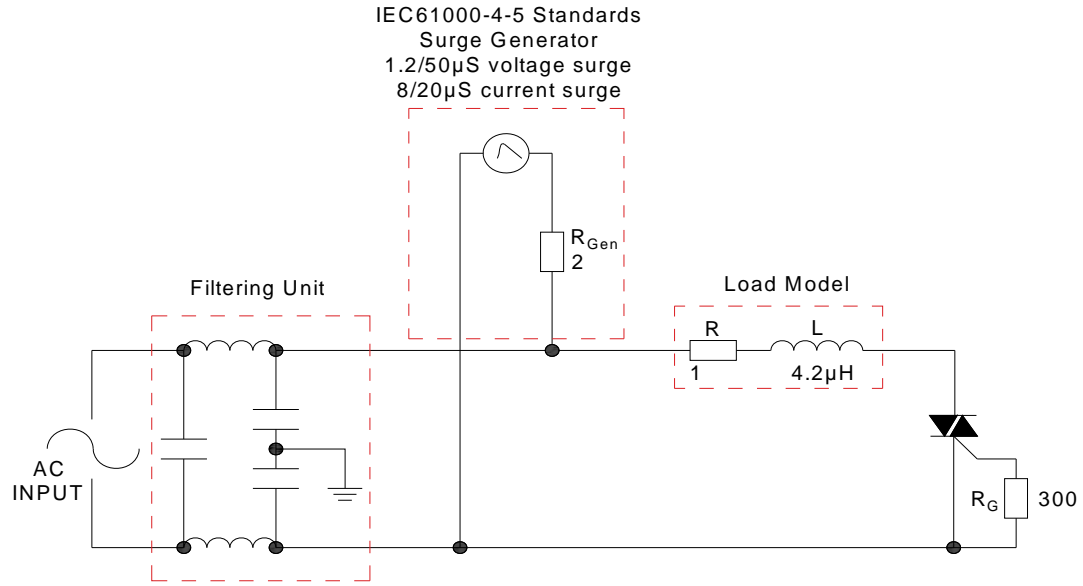

FIG.7 Test circuit for inductive and resistive loads to IEC-61000-4-5 standards



### SHAPING AND SOLDERING PARAMETERS

Refer to Instructions for installation of plastic-sealed in-line power devices released by JieJie

**ORDERING INFORMATION**

Order code	Voltage $V_{DRM}/V_{RRM}$ (V)	IGT(mA)	Package	Base qty. (pcs)	Delivery mode
		- -			
T2050H-6F	600	50	TO-220F(Ins)	50	Tube

**Document Revision History**

Date	Revision	Changes
Apr.10, 2023	A.1.0	Last updated

PACKAGE MECHANICAL DATA

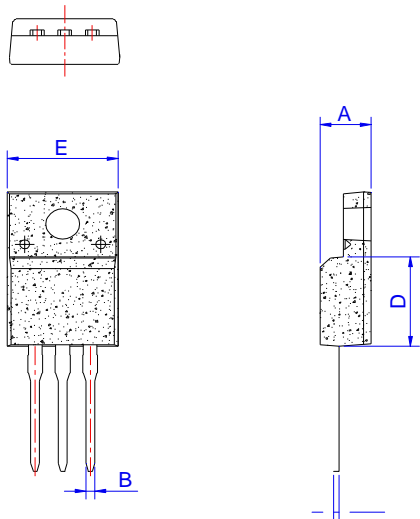

Information furnished in this document is believed to be accurate and reliable. However, Jiangsu JieJie Microelectronics Co., Ltd. assumes no responsibility for the consequences of use without consideration for such information nor use beyond it. Information mentioned in this document is subject to change without notice, apart from that when an agreement is signed, Jiangsu JieJie complies with the agreement.

Products and information provided in this document have no infringement of patents. Jiangsu JieJie assumes no responsibility for any infringement of other rights of third parties which may result from the use of such products and information. This document supersedes and replaces all information previously supplied.



is a registered trademark of Jiangsu JieJie Microelectronics Co., Ltd.

Copyright ©2023 Jiangsu JieJie Microelectronics Co., Ltd. Printed All rights reserved.