f

.....



ELECTRICAL CHARACTERISTICS

STATIC CHARACTERISTICS

THERMAL RESISTANCES

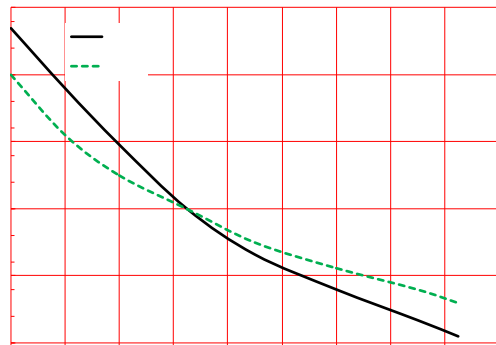
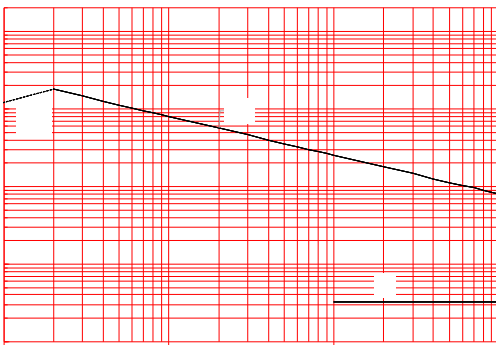
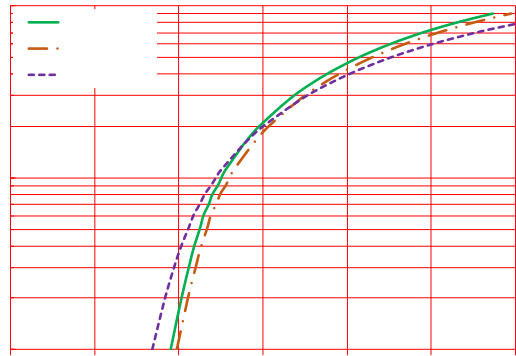
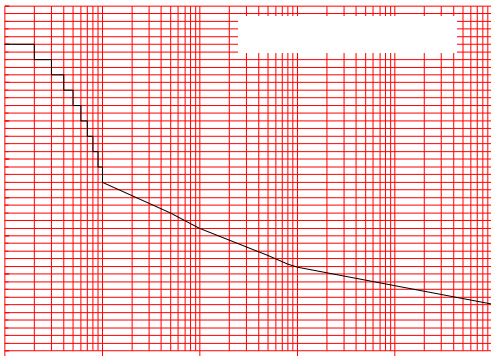
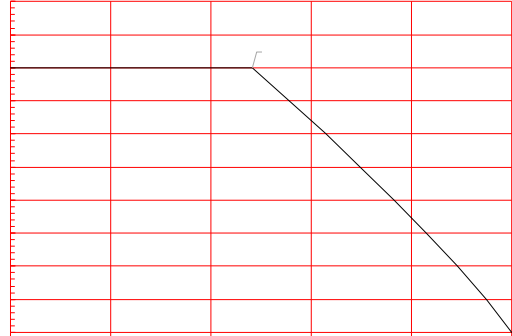
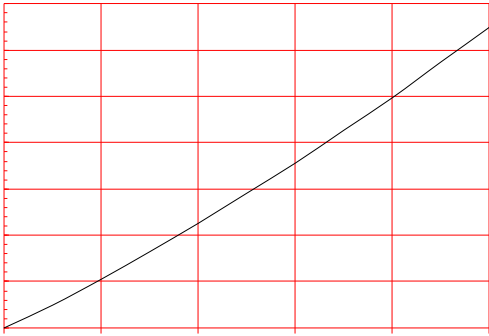

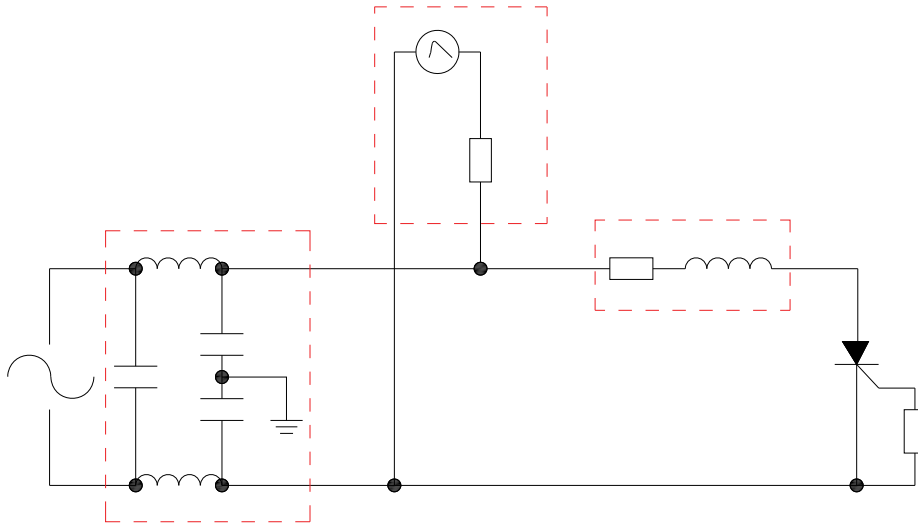

SHAPING AND SOLDERING PARAMETERS



ORDERING INFORMATION

PACKAGE MECHANICAL DATA

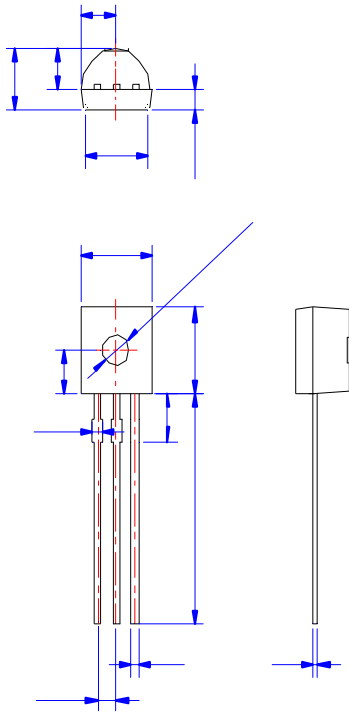



DELIVERY MODE

