



JCT812TC 12A SCR

Rev.A.1.0

JCT812TC silicon controlled rectifier is specifically designed for medium power switching and phase control applications. High current density due to mesa technology; SIPOS and Glass Passivation

nectioa tumperuru o



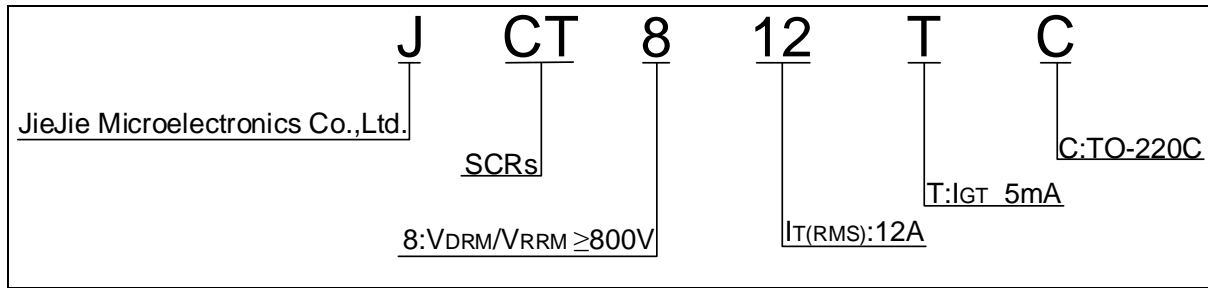

FIG.1 Maximum power dissipation versus RMS on-state current

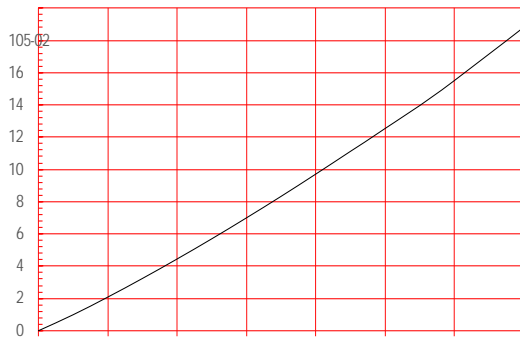
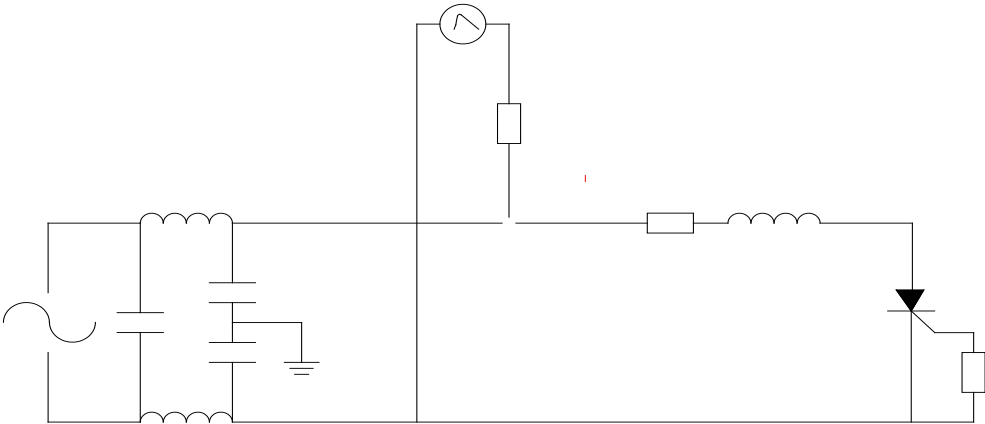

FIG.2: RMS on-state current versus case temperature

FIG.7 Test circuit for inductive and resistive loads to IEC-61000-4-5 standards.



| Order code | Voltage V_{DRM}/V_{RRM} (V) | IGT(mA) | Package | Base qty. (pcs) | Delivery mode |
|------------|----------------------------------|---------|---------|--------------------|------------------|
| JCT812TC | 800 | 5 | TO-220C | 50 | Tube |

Document Revision History

| Date | Revision | Changes |
|--------------|----------|-------------|
| Apr.13, 2023 | A.1.0 | Last update |

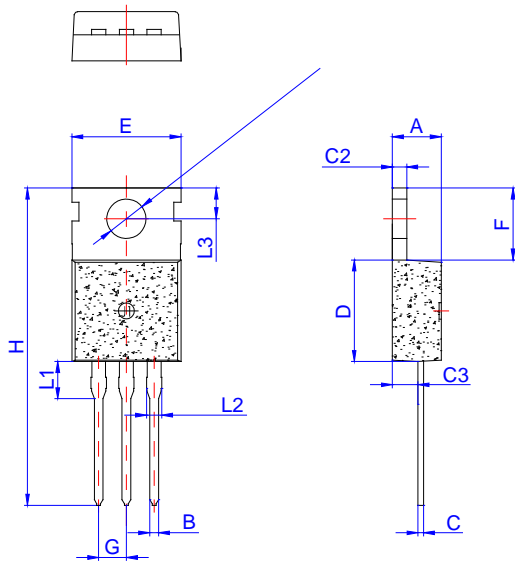

| Ref. | Dimensions | | | | | |
|------|-------------|------|------|--------|------|-------|
| | Millimeters | | | Inches | | |
| | Min. | Typ. | Max. | Min. | Typ. | Max. |
| A | 4.40 | | 4.60 | 0.173 | | 0.181 |
| B | 0.70 | | 0.90 | 0.028 | | 0.035 |
| C | 0.45 | | 0.60 | 0.018 | | 0.024 |
| C2 | 1.25 | | 1.35 | 0.049 | | 0.053 |
| C3 | 2.20 | | 2.60 | 0.087 | | 0.102 |
| D | 8.90 | | 9.90 | 0.350 | | 0.390 |
| E | 9.90 | | 10.3 | 0.390 | | 0.406 |
| F | 6.30 | | 6.90 | 0.248 | | 0.272 |
| G | 2.40 | | 2.70 | 0.094 | | 0.106 |
| H | 28.0 | | 29.8 | 1.102 | | 1.173 |
| L1 | 2.70 | | 3.30 | 0.106 | | 0.130 |
| L2 | 1.14 | | 1.70 | 0.045 | | 0.067 |
| L3 | 2.65 | | 2.95 | 0.104 | | 0.116 |

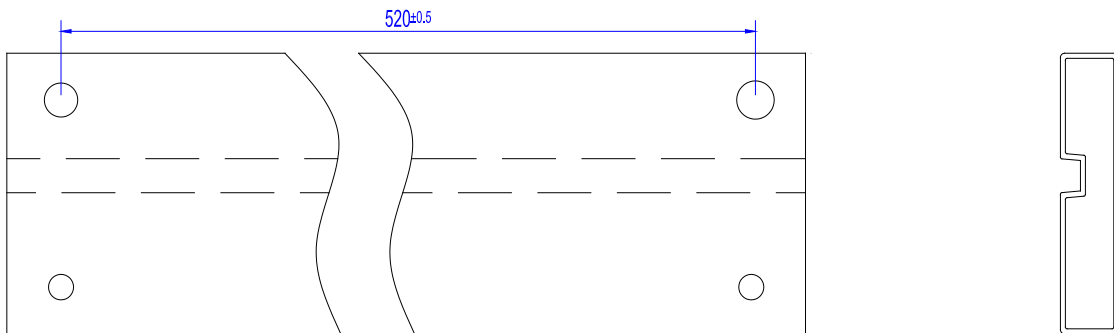

Information furnished in this document is believed to be accurate and reliable. However, Jiangsu JieJie Microelectronics Co., Ltd. assumes no responsibility for the consequences of use without consideration for such information nor use beyond it. Information mentioned in this document is subject to change without notice, apart from that when an agreement is signed, Jiangsu JieJie complies with the agreement. Products and information provided in this document have no infringement of patents. Jiangsu JieJie assumes no responsibility for any infringement of other rights of third parties which may result from the use of such

67Tj 0.002 Tc -0.004 Tw 3.26 0 Td [(f)-18