

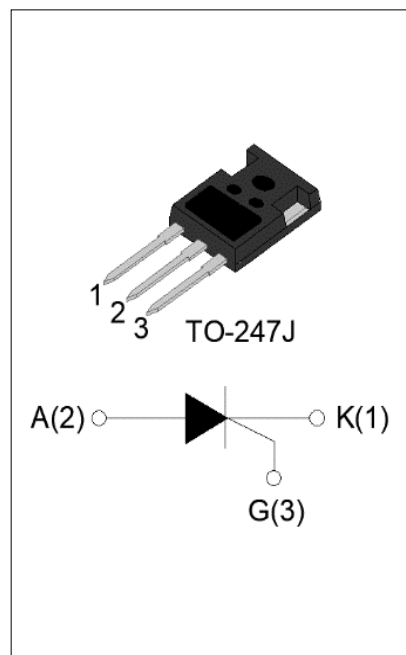

With high ability to withstand the shock loading of large current, JCT655SJ SCR provides high dV/dt rate with strong resistance to electromagnetic interference. It is especially recommended for use on solid state relay, motorcycle, power charger, T-tools etc. Package TO-247J is RoHS compliant.

Symbol	Value	Unit
$I_{T(RMS)}$	55	A
V_{DRM}/V_{RRM}	600	V
I_{GT}	10-50	mA



Parameter	Symbol	Value	Unit
Storage junction temperature range	T_{stg}	-40-150	
Operating junction temperature range	T_j	-40-125	
Repetitive peak off-state voltage ($T_j=25^\circ\text{C}$)	V_{DRM}	600	V
Repetitive peak reverse voltage ($T_j=25^\circ\text{C}$)	V_{RRM}	600	V
Average on-state current ($T_c = 87^\circ\text{C}$)	$I_{T(AV)}$	35	A
RMS on-state current ($T_c = 87^\circ\text{C}$)	$I_{T(RMS)}$	55	A
Non repetitive surge peak on-state current ($t_p=10\text{ms}, T_j=25^\circ\text{C}$)	I_{TSM}	700	A
Non repetitive surge peak on-state current ($t_p=8.3\text{ms}, T_j=25^\circ\text{C}$)		750	
I^2t value for fusing ($t_p=10\text{ms}, T_j=25^\circ\text{C}$)	I^2t	2450	A^2s
Critical rate of rise of on-state current ($I_G=2 I_{GT}, f=100\text{Hz}, T_j=125^\circ\text{C}$)	di/dt	200	$\text{A}/\mu\text{s}$
Peak gate current ($t_p=20\mu\text{s}, T_j=125^\circ\text{C}$)	I_{GM}	10	A
Average gate power dissipation ($T_j=125^\circ\text{C}$)	$P_{G(AV)}$	1	W

Peak gate power	P_{GM}	20	W
Peak pulse voltage ($T_j=25$; non-repetitive,off-state;FIG.7)	V_{pp}	0.7	kV

($T_j=25$ unless otherwise specified)

Symbol	Test Condition	Value			Unit
		MIN.	TYP.	MAX.	
I_{GT}	$V_D=12V R_L=33$	10	-	50	mA
V_{GT}		-	-	1	V
V_{GD}	$V_D=V_{DRM} T_j=125 R_L=3.3K$	0.2	-	-	V
I_L	$I_G=1.2I_{GT}$	-	-	120	mA
I_H	$I_T=500mA$	-	-	100	mA

dV/dt V_D A mAe

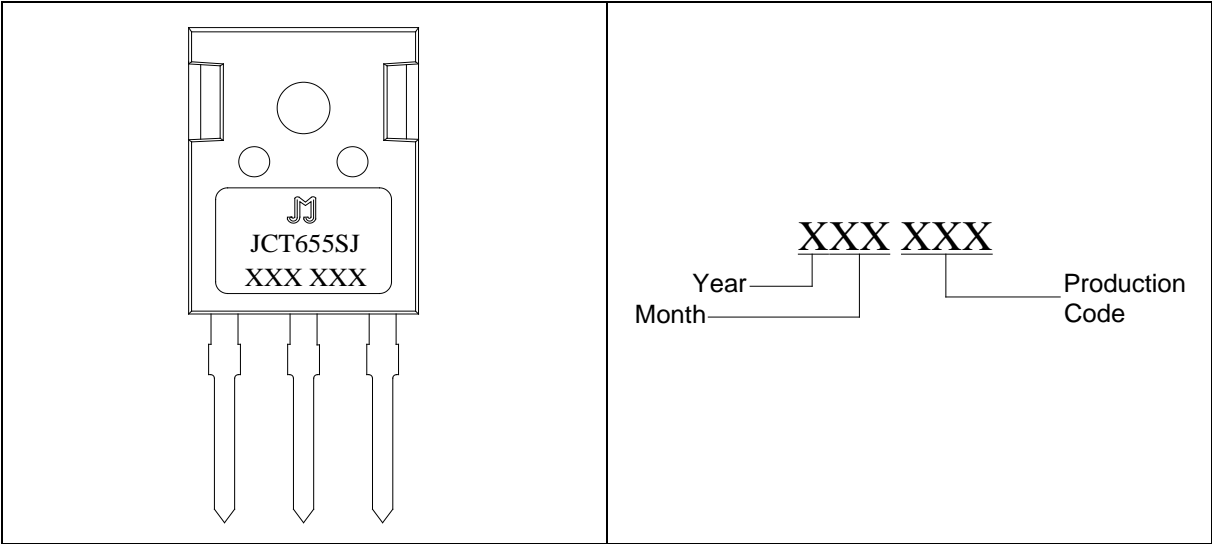
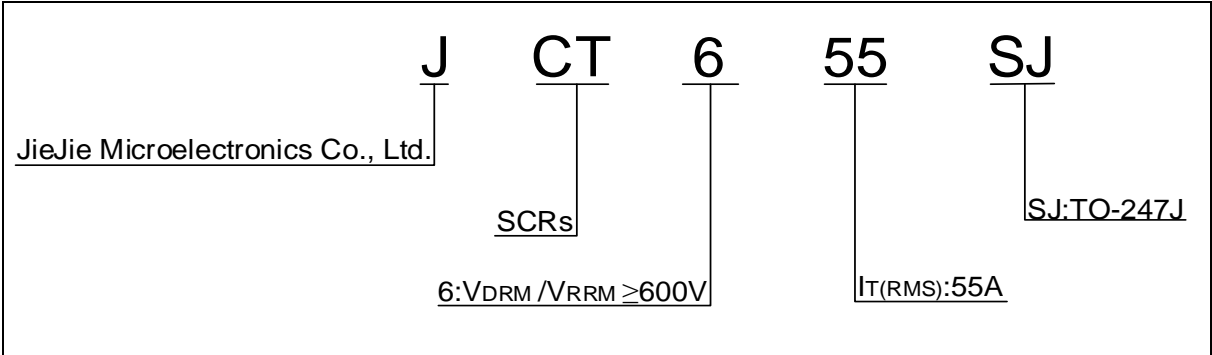

FIG.1 Maximum power dissipation versus RMS on-state current

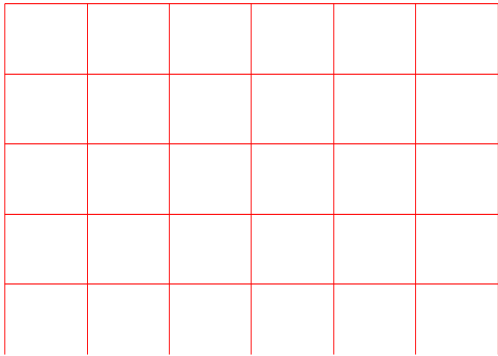
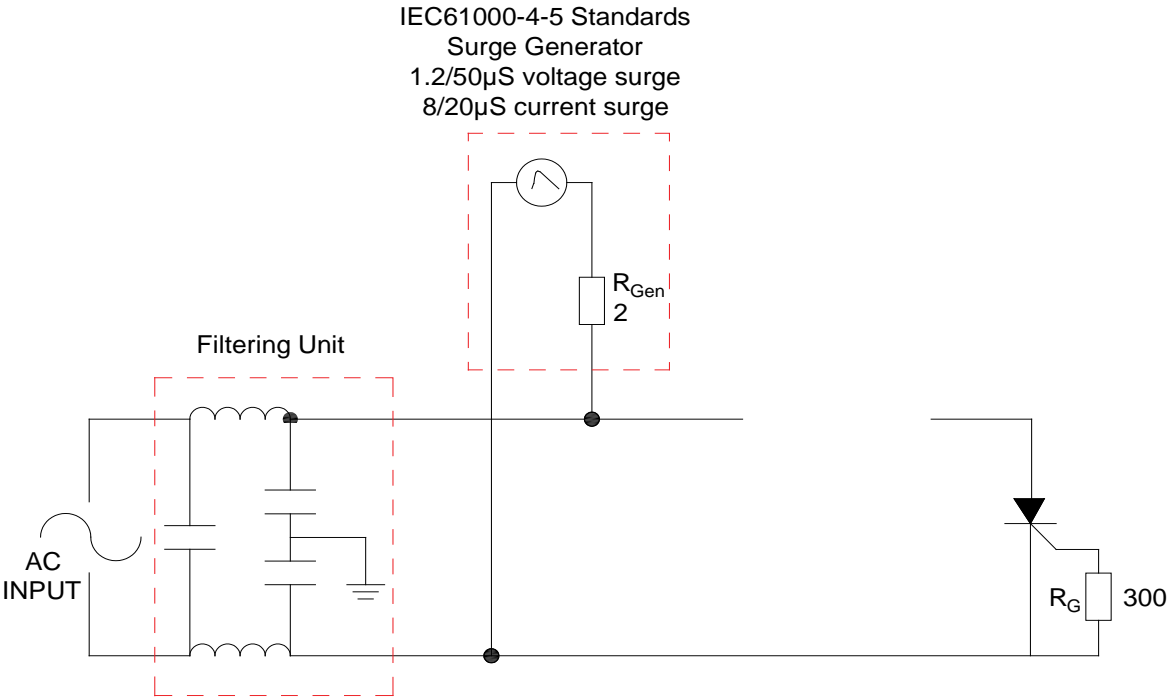

FIG.2: RMS on-state current versus case temperature

FIG.7 Test circuit for inductive and resistive loads to IEC-61000-4-5 standards.



Order code	Voltage V_{DRM}/V_{RRM} (V)	IGT(mA)	Package	Base qty. (pcs)	Delivery mode
JCT655SJ	600	10-50	TO-247J	30	Tube

Document Revision History

Date	Revision	Changes
Apr.13, 2023	A.1.0	Last update

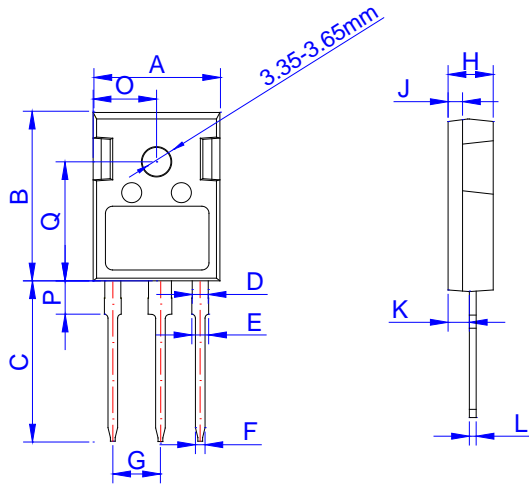

Ref.	Dimensions					
	Millimeters			Inches		
	Min.	Typ.	Max.	Min.	Typ.	Max.
A	15.50	15.80	16.10	0.610	0.622	0.634
B	20.80	21.00	21.20	0.819	0.827	0.835
C	19.70	20.00	20.30	0.776	0.787	0.799
D	1.80	2.00	2.20	0.071	0.079	0.087
E	1.90	2.10	2.30	0.075	0.083	0.091
F	1.00	1.20	1.40	0.039	0.047	0.055
G		5.44			0.214	
H	4.80	5.00	5.20	0.189	0.197	0.205
J	1.90	2.00	2.10	0.075	0.079	0.083
K	2.20	2.35	2.50	0.087	0.093	0.098
L	0.41	0.60	0.79	0.016	0.024	0.031
O		7.90			0.312	
P	4.05	4.15	4.25	0.016	0.024	0.031
Q		14.85			0.587	

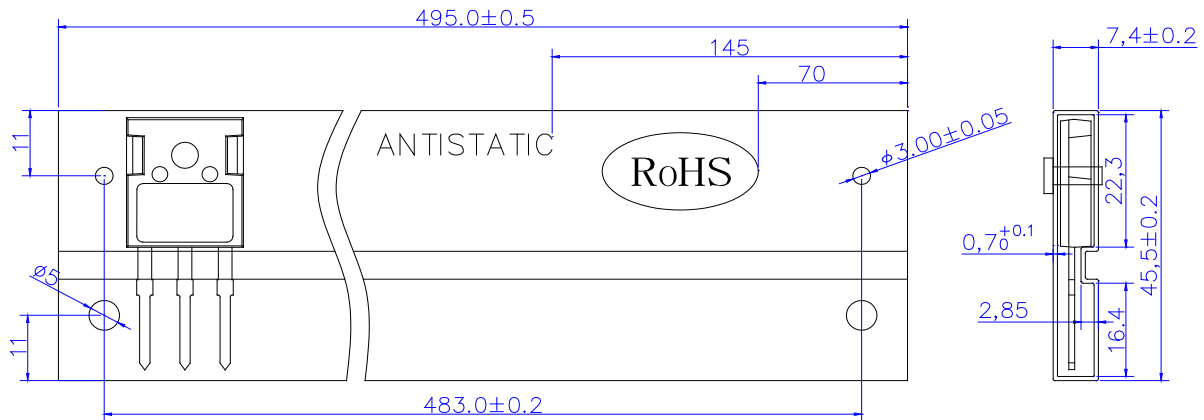

PACKAGE	OUTLINE	TUBE (PCS)	INNER BOX (PCS)	PER CARTON
TO-247J	TUBE	30	450	2,250

Information furnished in this document is believed to be accurate and reliable. However, Jiangsu JieJie Microelectronics Co., Ltd. assumes no responsibility for the consequences of use without consideration for such information nor use beyond it. Information mentioned in this document is subject to change without notice, apart from that when an agreement is signed, Jiangsu JieJie complies with the agreement. Products and information provided in this document have no infringement of patents. Jiangsu JieJie assumes no responsibility for any infringement of other rights of third parties which may result from the use of such products and information. This document supersedes and replaces all information previously supplied.

 is a registered trademark of Jiangsu JieJie Microelectronics Co., Ltd. Copyright © 2023 Jiangsu JieJie Microelectronics Co., Ltd. All rights reserved.