

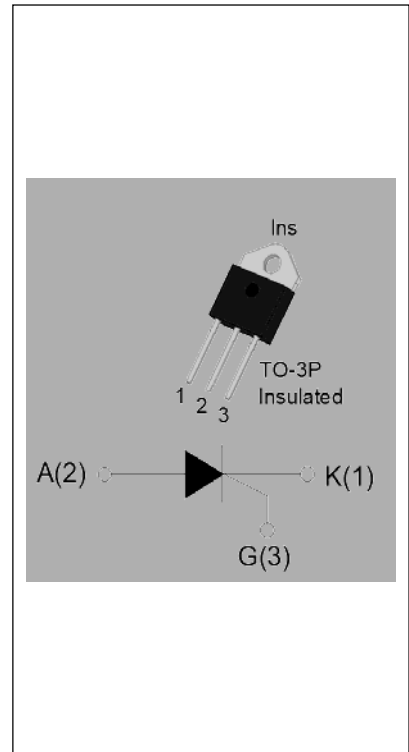

DESCRIPTION:

MAIN FEATURES



ABSOLUTE MAXIMUM RATINGS

x			



ELECTRICAL CHARACTERISTICS

STATIC CHARACTERISTICS

THERMAL RESISTANCES



ORDERING INFORMATION

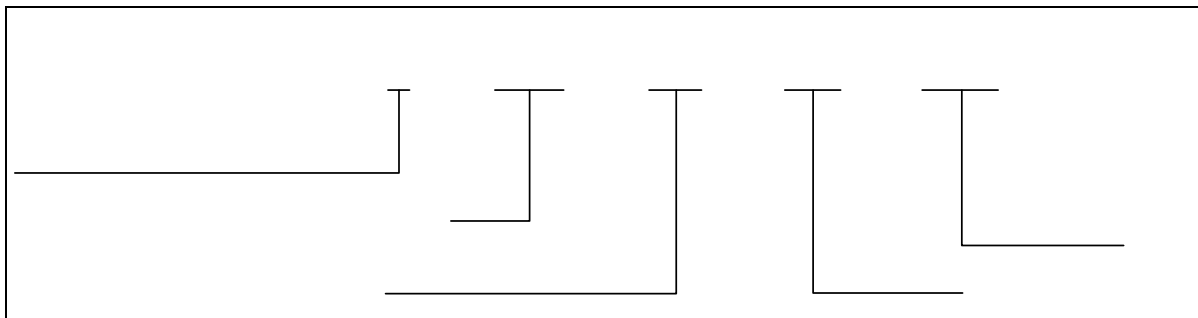

MARKING

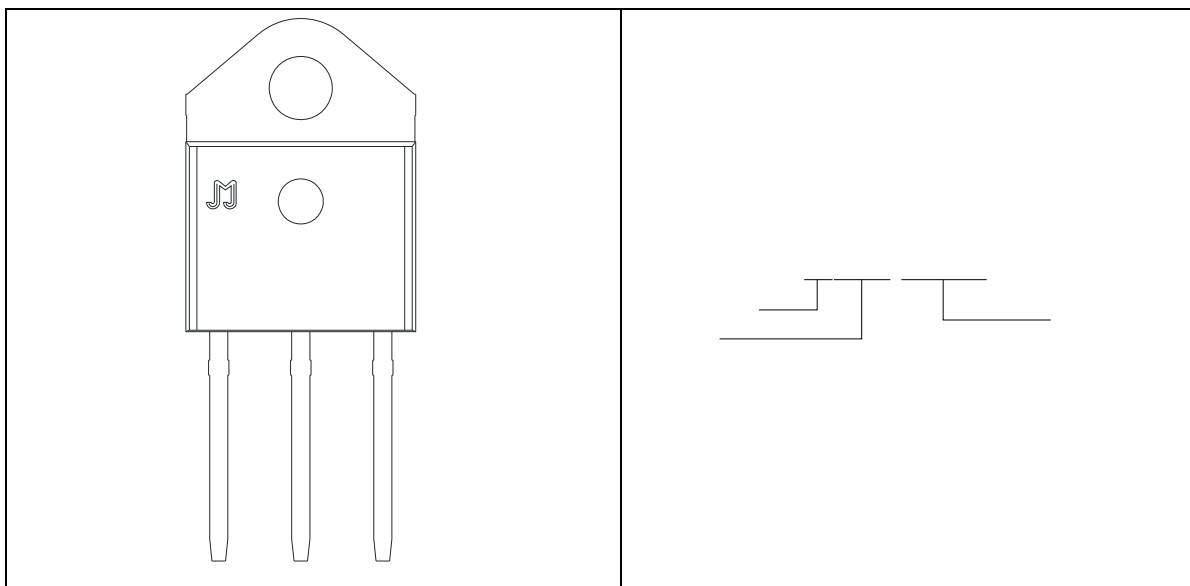

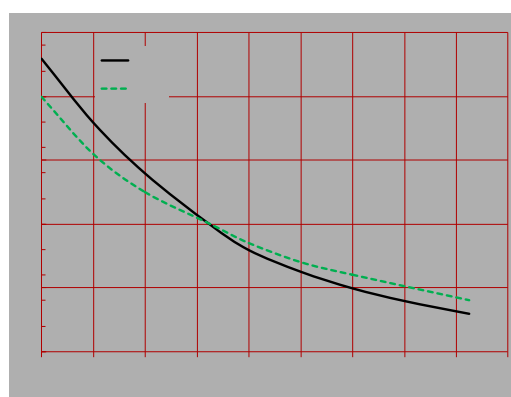
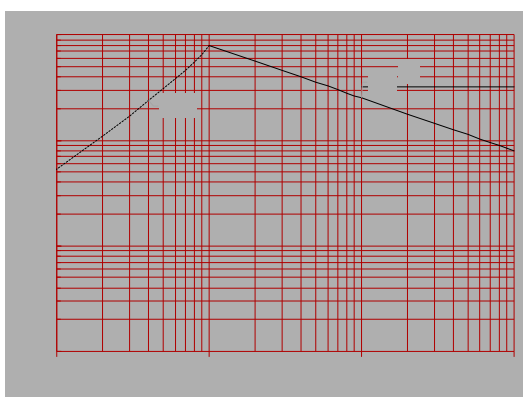
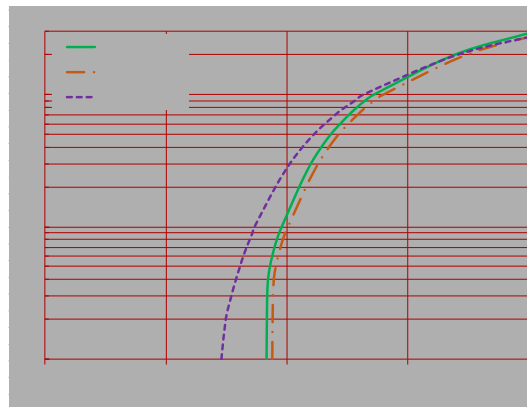
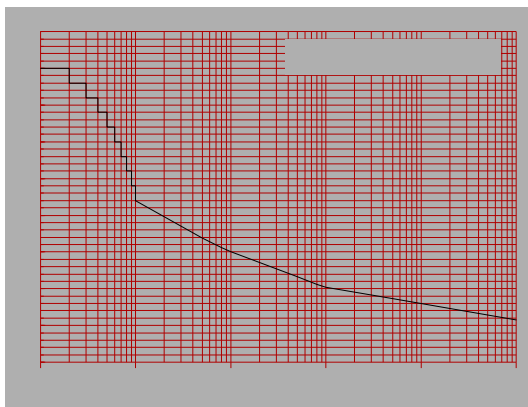
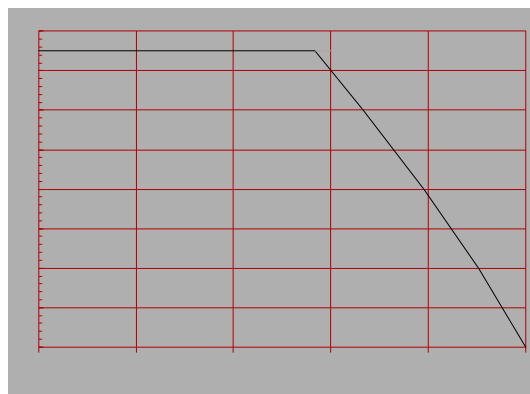
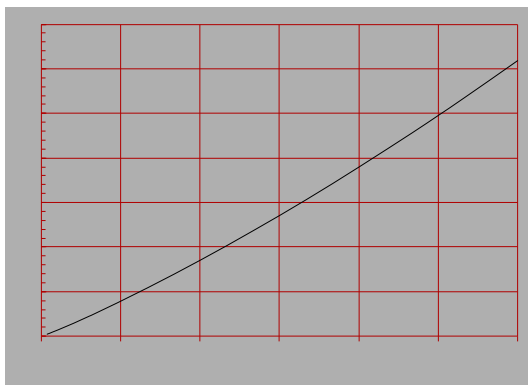

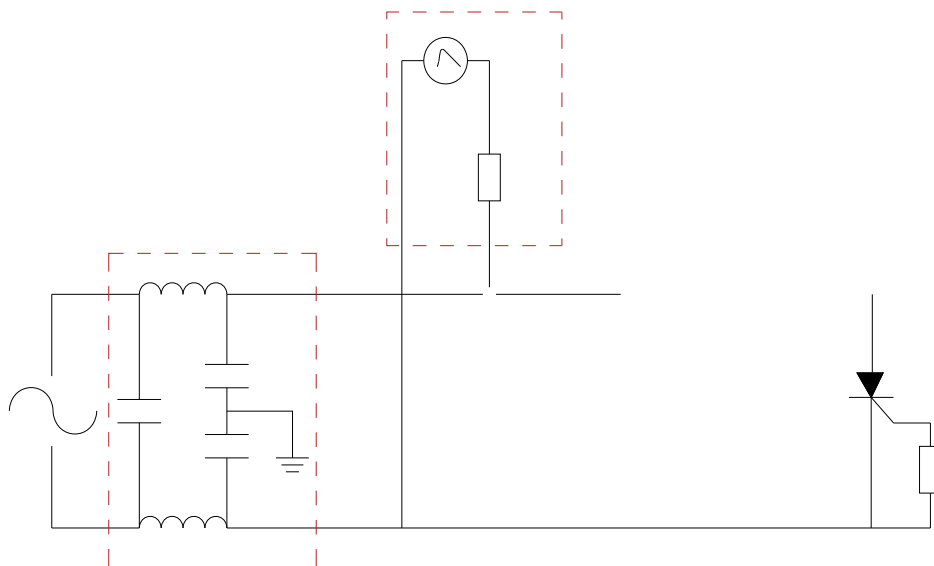



ORDERING INFORMATION



PACKAGE MECHANICAL DATA

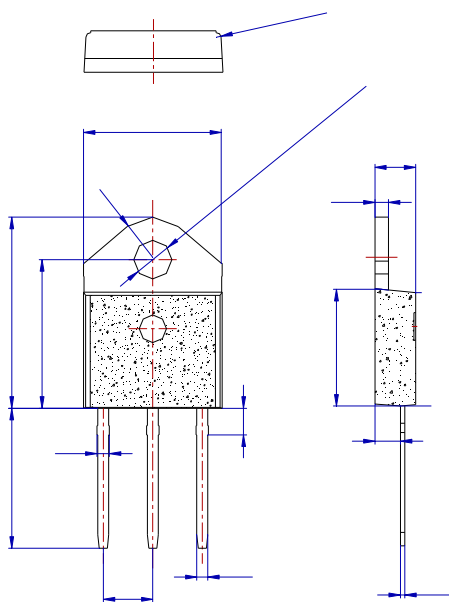

DELIVERY MODE



