



ACJT425-10F 4A TRIAC

Rev.A.1.0

DESCRIPTION:

The ACJT425-10F triac is suitable for general purpose AC switching. It can be used as an ON/OFF function in

C /P <</MCID 5 >>BDC91 0 scn w -2.004 Tw 0.33 0 6.63 /c 0 Tw 0.63 2 w 0.6Tj 01.4-/c 0 Tw 0.63 2

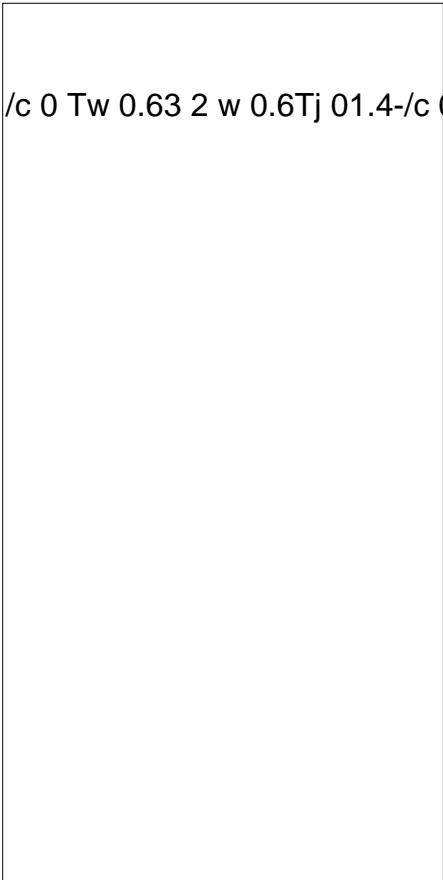

Average gate power dissipation ($T_j=125$)	$P_{G(AV)}$	0.5	W
Peak gate power	P_{GM}	10	W
Peak pulse voltage ($T_j=25$; non-repetitive,off-state;FIG.7)	V_{pp}	3.5	kV

ELECTRICAL CHARACTERISTICS (unless otherwise specified)

Symbol	Test Condition	Quadrant	Value		Unit
I_{GT}	$V_D=12V R_L=33$	- -	MAX.	25	mA
V_{GT}		- -	MAX.	1	V
V_{GD}	$V_D=V_{DRM} T_j=125$ $R_L=3.3K$	- -	MIN.	0.2	V
I_L	$I_G=1.2I_{GT}$	-	MAX.	40	mA
				60	
I_H	$I_T=100mA$		MAX.	35	mA
dV/dt	$V_D=670V$ Gate Open $T_j=125$		MIN.	1500	V/s
$(dI/dt)_c$	$V_D=125V$ $T_j=125$		MIN.	8	A/ms
t_{on}	$I_G=40mA I_A=200mA I_R=20mA$ $T_j=25$		TYP.	5	s
t_{off}				70	
V_{CL}	$I_{CL}=0.1mA t_p=1ms$		MIN.	1050	V

STATIC CHARACTERISTICS

Symbol	Parameter		Value(MAX.)	Unit
V_{TM}	$I_{TM}=5.6A t_p=380$ s	$T_j=25$	1.55	V
V_{TO}	Threshold voltage	$T_j=125$	0.73	V
R_D	Dynamic resistance	$T_j=125$	171	P
I_{DRM}	$V_D=V_{DRM} V_R=V_{RRM}$	$T_j=25$	8	A
I_{RRM}		$T_j=125$	0.4	mA

THERMAL RESISTANCES

Symbol	Parameter	Value	Unit
$R_{th(j-c)}$	junction to case (AC)	3.5	$^{\circ}W$
$R_{th(j-a)}$	junction to ambient (AC)	60	$^{\circ}W$

ORDERING INFORMATION

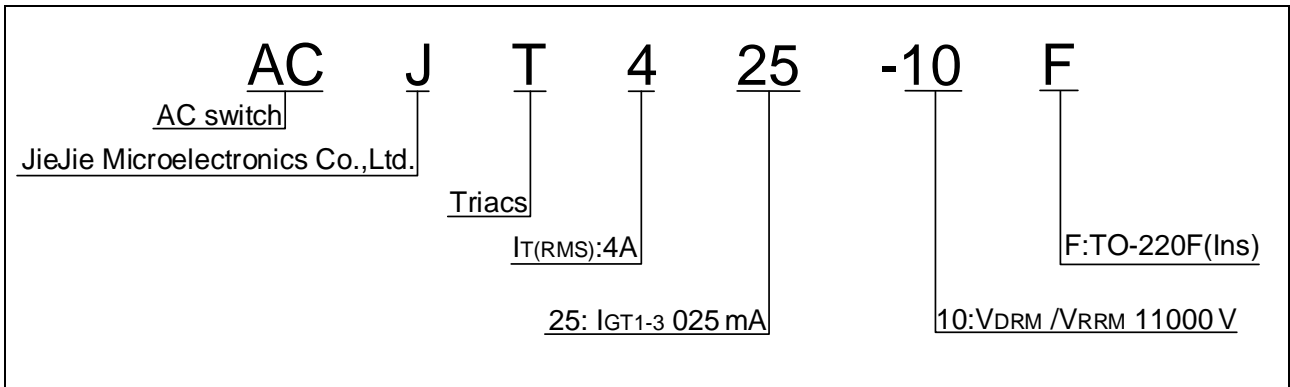

MARKING

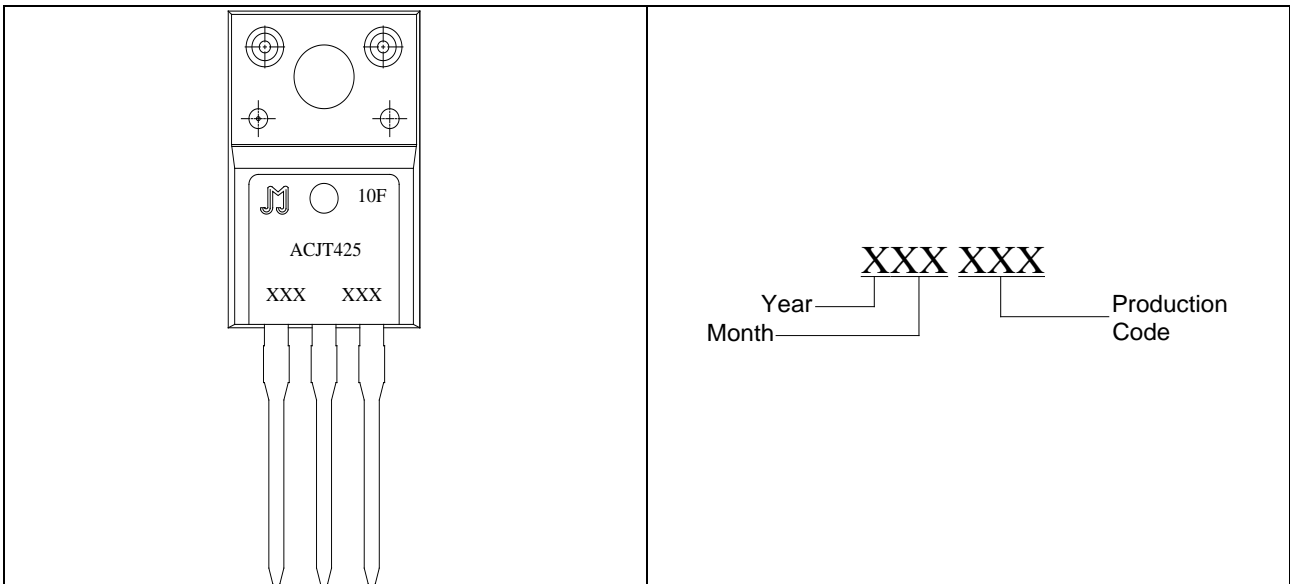

FIG.1 Maximum power dissipation versus RMS on-state current

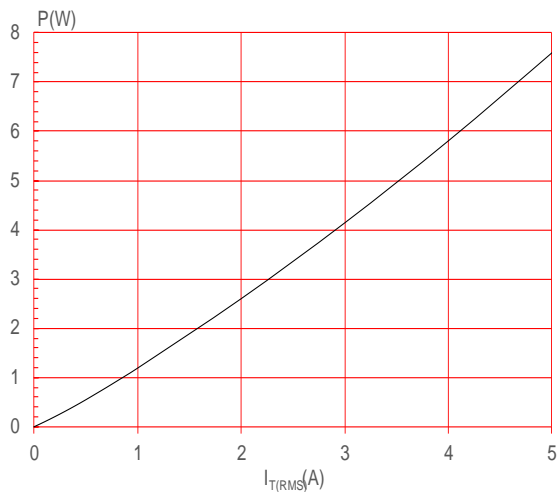

FIG.3: Surge peak on-state current versus number of cycles

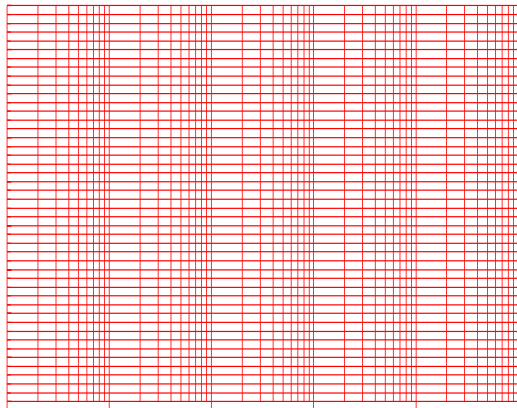

FIG.2: RMS on-state current versus case temperature

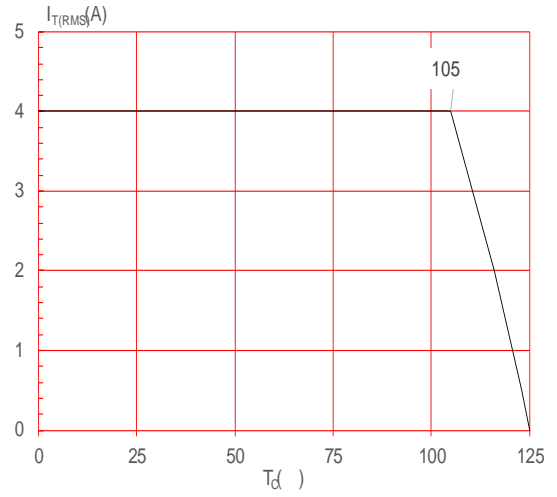
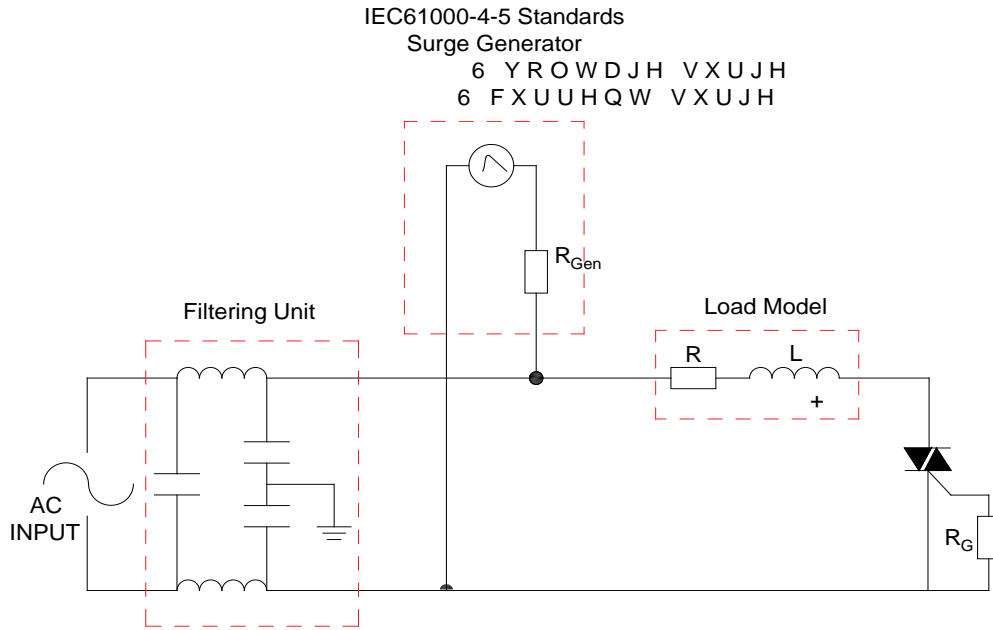

FIG.4: On-state characteristics

FIG.7 ÖTest circuit for inductive and resistive loads to IEC-61000-4-5 standards



ORDERING INFORMATION

Order code	Voltage V_{DRM}/V_{RRM} (V)	IGT(mA)	Package	Base qty. (pcs)	Delivery mode
ACJT425-10F	1000	25	TO-220F(Ins)	50	Tube

Document Revision History

Date	Revision	Changes
Apr.14, 2023	A.1.0	Last updated

PACKAGE MECHANICAL DATA

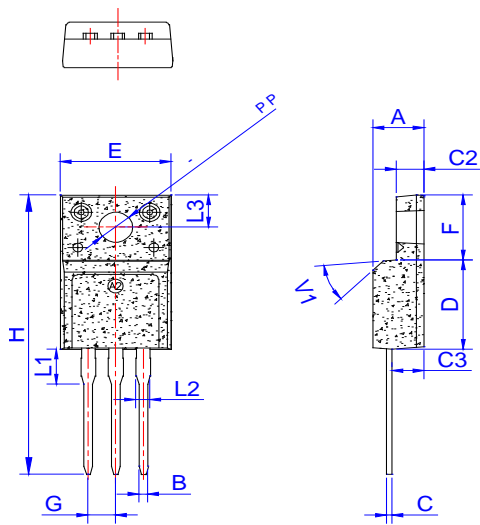

Ref.	Dimensions					
	Millimeters			Inches		
	Min.	Typ.	Max.	Min.	Typ.	Max.
A	4.50		4.90	0.177		0.193
B	0.74	0.80	0.83	0.029	0.031	0.033
C	0.47		0.65	0.019		0.026
C2	2.45		2.75	0.096		0.108
C3	2.60		3.00	0.102		0.118
D	8.80		9.30	0.346		0.366
E	9.80		10.4	0.386		0.410
F	6.40		6.80	0.252		0.268
G	2.40		2.70	0.094		0.106
H	28.0		29.8	1.102		1.173
L1	3.20		3.80	0.126		0.150
L2	1.14		1.70	0.045		0.067
L3	3.20		3.60	0.126		0.142
V1		45°			45°	

DELIVERY MODE

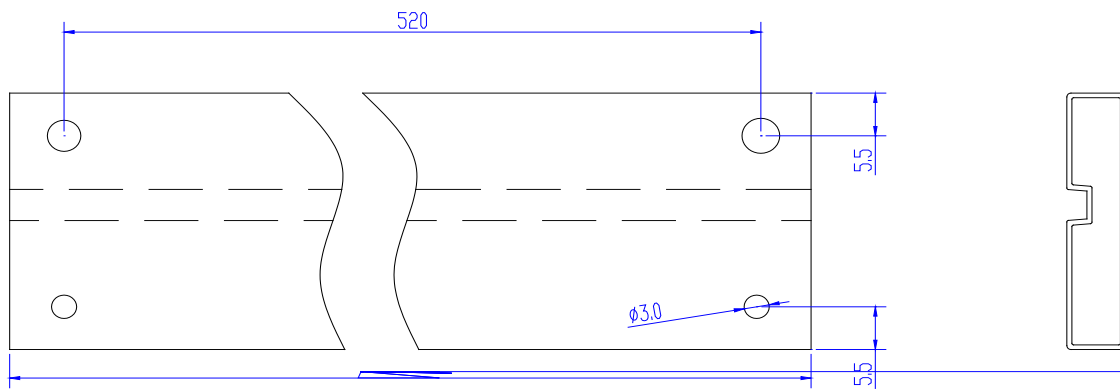

Information furnished in this document is believed to be accurate and reliable. However, Jiangsu JieJie Microelectronics Co., Ltd. assumes no responsibility for the consequences of use without consideration for such information nor use beyond it. Information mentioned in this document is subject to change without notice, apart from that when an agreement is signed, Jiangsu JieJie complies with the agreement.

Products and information provided in this document have no infringement of patents. Jiangsu JieJie assumes no responsibility for any infringement of other rights of third parties which may result from the use of such products and information. This document supersedes and replaces all information previously supplied.



is a registered trademark of Jiangsu JieJie Microelectronics Co., Ltd.

Copyright ©2023 Jiangsu JieJie Microelectronics Co., Ltd. Printed All rights reserved.